

MagneW Two-wire PLUS

Smart Two-wire Electromagnetic Flowmeter

Model MTG18A (Integral type)

Model MTG14C/MTG18B (Remote type)

OVERVIEW

The MagneW Two-wire PLUS is a high performance electromagnetic flowmeter based on field proven Yamatake two-wire loop powered technology. The MagneW Two-wire PLUS offers the stable and accurate measurement of a traditional magflow meter with low power consumption. The result is a lower overall cost of ownership.

FEATURES

Two-wire operation

MagneW Two-wire PLUS significantly reduces installation costs when compared to a traditional four wired magnetic flowmeter.

High accuracy and stable output

MagneW Two-wire PLUS provides high accuracy ($\pm 0.5\%$ of rate) and its output is as stable as current four wired magnetic flowmeters.

Minimum measurable fluid conductivity

The MagneW Two-wire PLUS offers a minimum process fluid conductivity of $10\mu\text{S}/\text{cm}$ which is the best among two-wire magflow meters thereby maximizing applicability.

Wider range in size

MagneW Two-wire PLUS offers wider range in detector size.

Detector size: 2.5 to 200 mm.

Wafer and flange style, integral and remote style available

The MagneW Two-wire PLUS is available integral or remote, flanged or wafer, making the selection of the right meter for the application simple.



Integral type

Remote type

APPLICATIONS

- Corrosive liquid measurement
- Chemical solution measurement
- Drainage/waste disposal fluid measurement
- Drinking water and waste water service
- Industrial/agricultural water measurement
- Seawater measurement

FUNCTIONAL SPECIFICATIONS

Enclosure rating

NEMA TYPE 4X, IEC IP67

Hazardous Areas certifications

Integral type

FM approval

<for Division 1>

Class I, Division 1, Groups A, B, C & D, T4;
 Class II, Division 1, Groups E, F & G, T4;
 Class III, T4, $-20^{\circ}\text{C} \leq \text{Tamb}^* \leq +60^{\circ}\text{C}$

<for Division 2>

Nonincendive for

Class I, Division 2, Groups A, B, C & D, T4;
 Class II, Division 2, Groups F & G, T4;
 Class III, T4; Class I, Zone 2, Group IIC, T4,
 $-20^{\circ}\text{C} \leq \text{Tamb}^* \leq +60^{\circ}\text{C}$

*Tamb = Ambient Temperature

CSA certification

<for Division 1>

Class I, Division 1, Groups A, B, C & D, T4;
 Class II, Division 1, Groups E, F & G, T4;
 Class III, T4, $-20^{\circ}\text{C} \leq \text{Tamb} \leq +60^{\circ}\text{C}$

<for Division 2>

Class I, Division 2, Groups A, B, C, & D, T4;
 Class II, Division 2, Groups E, F & G, T4;
 Class III, T4, $-20^{\circ}\text{C} \leq \text{Tamb}^* \leq +60^{\circ}\text{C}$

*Tamb = Ambient Temperature

Remote type

FM approval

<for Division 2>

Nonincendive for

Class I, Division 2, Groups A, B, C & D, T4;
 Class II, Division 2, Groups F & G, T4;
 Class III, T4; Class I, Zone 2, Group IIC, T4,
 $-20^{\circ}\text{C} \leq \text{Tamb}^* \leq +60^{\circ}\text{C}$

*Tamb = Ambient Temperature

CSA certification

<for Division 2>

Class I, Division 2, Groups A, B, C & D, T4;
 Class II, Division 2, Groups E, F & G, T4;
 Class III, T4, $-20^{\circ}\text{C} \leq \text{Tamb}^* \leq +60^{\circ}\text{C}$

*Tamb = Ambient Temperature

Output signal

Analog output

4 to 20 mA DC

Digital output

DE

Analog or Digital output is selectable.

Pulse output

Open collector output (30V DC, 100 mA max.)

Pulse frequency: 0.0001 to 200 Hz

Pulse width: 1 ms to 1 s

Voltage drop during transistor ON : 1.6 Vmax.

Contact output

Open collector output (30V DC, 100 mA max.)

Pulse or contact output is selectable

Communication protocol

SFC communication and HART communication

Load resistance characteristic of communication

External power supply 21.05 to 42V DC for communication.

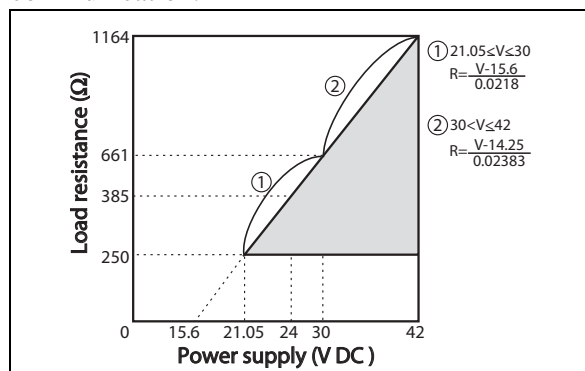

Note) The load resistance of 250 Ω or more is necessary for communications of SFC and the HART communicator.

Flow unit

Volume flow: m³, L, cm³, G (gallon), mG, kG,
 B (barrel), IG (imperial gallon), mIG,
 kIG

Mass flow: t, kg, g, lb

Time: d, h, min, s

Display

Display: LCD

Main display: 7-segment, 8 digits

Sub display: 16 digits, 2 lines

Display contents:

Simultaneously displays % flow rate, Actual flow rate (eng. unit) and Totalized value.

Data setting

Operation by four key switches

Damping

Adjustable between 0.5 and 199.9 seconds.

Low flow cutoff

Adjustable between 0 and 10% of setting range.

Below selected value, output is driven to the zero flow rate signal level.

Dropout

Adjustable between 0 and 10% of setting range.

Below selected value, pulse output is cut.

Empty pipe detection

Detect empty pipe condition by monitoring flow rate signal. Once the flow rate signal fluctuates over a certain threshold, the device judges that the detector is empty. When the detector is empty, the analog output (4 to 20mA output) and pulse output are set to zero flow values. The display alternately shows zero value and "Empty Status".

There are three threshold levels to meet an environment where the device is installed. Set an appropriate threshold level from below.

SENSITIVITY HIGH

SENSITIVITY MID

SENSITIVITY LOW

Default setting: OFF

Operating condition :

The following conditions must be met when using the empty pipe detection function.

- Diameter: 10mm or larger
- Electric conductivity of fluid: 30 μS/cm or greater
- Grounding: Grounding resistance must be less than 100Ω
- The noise level must be over the set threshold when the pipe is empty.

The noise level must be under the set threshold when the process fluid flows in the detector.

Lightning protection

12 kV, 1000A

Equipped with the lightning arrester in the power source and external output terminals.

Power failure

An EEPROM retains data record of totalized value when pulse output is used (retention period approximately 10 years).

Power supply

15.6 to 42V DC (without communication)

21.05 to 42V DC (with communication)

Size

Wafer style

25, 40, 50, 65, 80, 100 mm (1, 1½, 2, 2½, 3, 4 inches)

Flange style

2.5, 5 mm (0.1, 0.2 inch) (Model MTG18A only)
10, 15, 25, 40, 50, 65, 80, 100, 150, 200 mm (3/8, 1/2, 1, 1½, 2, 2½, 3, 4, 6, 8 inches)

Flange rating

ANSI150, ANSI300, DIN PN10, DIN PN16, DIN PN25, JIS10K, JIS20K, JIS30K

Ambient temperature limits

-20 to 60°C (-4 to 140°F)

Ambient humidity limits

10 to 90% RH

Temperature range and pressure range of process fluid

Refer to the following.

Size: 2.5 to 10 mm (0.1 to 3/8 inch)

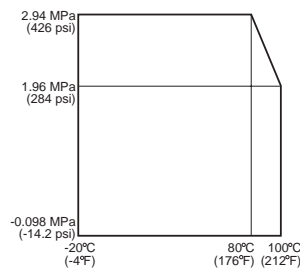

Size: 15 to 200 mm (1/2 to 8 inch)

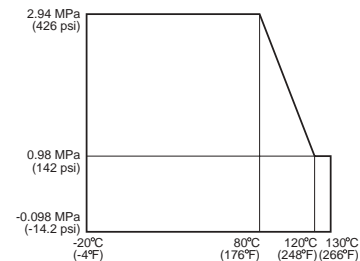

Measurable electrical conductivity

10 μS/cm or greater

50 μS/cm or greater (10 mm (3/8 inch), 15 mm (1/2 inch) for remote type)

Measurement flow range

Size		Maximum flow velocity range is 0 to 0.3 m/s (0 to 0.98 ft/s)		Maximum flow velocity range is 0 to 10 m/s (0 to 32.8 ft/s)		Conversion factor K
		Minimum range		Maximum range		
mm	inches	m ³ /h	GPM	m ³ /h	GPM	
2.5	0.1	0 to 0.00531	0 to 0.02335	0 to 0.1767	0 to 0.778	56.59
5	0.2	0 to 0.02121	0 to 0.09337	0 to 0.7068	0 to 3.112	14.15
10	3/8	0 to 0.08483	0 to 0.3735	0 to 2.827	0 to 12.44	3.537
15	1/2	0 to 0.1909	0 to 0.8404	0 to 6.361	0 to 28.01	1.572
25	1	0 to 0.5302	0 to 2.335	0 to 17.67	0 to 77.80	0.5659
40	1½	0 to 1.358	0 to 5.976	0 to 45.23	0 to 199.1	0.2210
50	2	0 to 2.121	0 to 9.337	0 to 70.68	0 to 311.2	0.1415
65	2½	0 to 3.584	0 to 15.78	0 to 119.4	0 to 525.9	0.08371
80	3	0 to 5.429	0 to 23.90	0 to 180.9	0 to 796.7	0.05526
100	4	0 to 8.483	0 to 37.35	0 to 282.7	0 to 1244	0.03537
150	6	0 to 19.09	0 to 84.04	0 to 636.1	0 to 2801	0.01572
200	8	0 to 33.93	0 to 149.4	0 to 1130	0 to 4979	0.008842

Velocity V (m/s) = K × Q

K = Conversion factor = 1/3600 × 4/(πD²) × 1000², D = Size (mm), Q = Flow rate (m³/h)

PERFORMANCE SPECIFICATIONS

Analog output accuracy

Size: 2.5, 5 mm (0.1, 0.2 inch)

V_s = velocity of setting range (m/s)

<i>V_s</i> (m/s)	Velocity during measurement $\geq V_s \times 50\%$	Velocity during measurement $\leq V_s \times 50\%$
$1.0 \leq V_s \leq 10$	$\pm 0.5\%$ of rate	$\pm 0.5\%$ of <i>V_s</i>
$0.3 \leq V_s \leq 1.0$	$\pm \frac{0.5}{V_s} \%$ of rate	$\pm 0.5 \left(\frac{0.5}{V_s} \right) \%$

Size: 10, 15 mm (3/8, 1/2 inch)

V_s = velocity of setting range (m/s)

<i>V_s</i> (m/s)	Velocity during measurement $\geq V_s \times 40\%$	Velocity during measurement $\leq V_s \times 40\%$
$1.0 \leq V_s \leq 10$	$\pm 0.5\%$ of rate	$\pm 0.5\%$ of <i>V_s</i>
$0.3 \leq V_s \leq 1.0$	$\pm \frac{0.5}{V_s} \%$ of rate	$\pm 0.4 \left(\frac{0.5}{V_s} \right) \%$

Size: 25 to 200 mm (1 to 8 inches)

V_s = velocity of setting range (m/s)

<i>V_s</i> (m/s)	Velocity during measurement $\geq V_s \times 30\%$	Velocity during measurement $\leq V_s \times 30\%$
$1.0 \leq V_s \leq 10$	$\pm 0.5\%$ of rate	$\pm 0.5\%$ of <i>V_s</i>
$0.3 \leq V_s \leq 1.0$	$\pm \frac{0.5}{V_s} \%$ of rate	$\pm 0.3 \left(\frac{0.5}{V_s} \right) \%$

PHYSICAL SPECIFICATIONS

Converter case finishing

Standard

Baked acrylic paint

Corrosion-proof

Baked epoxy paint

Converter case material

Aluminum alloy

Display cover material

Tempered glass

Terminal box finishing (Model MTG18B only)

Standard: Baked acrylic paint

Corrosion-proof: Baked epoxy paint

Terminal box material (Model MTG18B only)

Aluminum alloy

Detector main body materials

Case material

Size 2.5 to 15 mm (0.1 to 1/2 inch):

SCS13 stainless steel

Size 25 to 200 mm (1 to 8 inches):

SUS304 stainless steel

Measuring pipe material

SUS304 stainless steel

Flange

SUS304 stainless steel

(size 2.5 to 65 mm (0.1 to 2½ inches))

Carbon steel + corrosion-preventive painting

(size 80 to 200 mm (3 to 8 inches))

Process wetted materials

Lining: PFA

Electrodes

SUS316L, ASTM B574 (Hastelloy C-276 equivalent), Titanium, Tantalum, Nickel, Zirconium, Platinum-Iridium

Grounding rings

SUS316, ASTM B575 (Hastelloy C-276 equivalent), Titanium, Tantalum, Zirconium, Platinum

INSTALLATION

Electrical connection

1/2NPT internal thread (must be selected for FM approval)

CM20 internal thread

G1/2 internal thread

Remote converter mounting

Wall mounting, 2-inch pipe mounting

Grounding

The grounding is essential for flow measurement.

The most effective grounding method is direct connection to earth ground with minimal impedance.

For approval selection code “1”, to maintain Intrinsic safety of system connect conductor to earth ground so that it has less than 1 Ohm to earth ground. See ANSI/ISA RP12.06.01 Installation of Intrinsically Safe Systems for Hazardous (Classified) Locations for guidance on installation of intrinsically safe apparatus and systems.

Pipe connection

Wafer style (Size: 25 to 100 mm (1 to 4 inches))

Flange style (Size: 2.5 to 200 mm (0.1 to 8 inches))

Length of straight pipe

Required straight pipe length clearance on the upstream side and the downstream side, while installing the detector.

Upstream side

A minimum 5D straight pipe length is required.

A minimum 10D straight pipe length is required if a diffuser/valve/pump is installed upstream side.

Downstream side

2D straight pipe length is recommended.

(Where D is the nominal bore diameter of the detector)

Cable between converter and detector

(Remote type)

Length

70 m (233 ft) or shorter

(25 mm (1 inch) to 200 mm (8 inches))

30 m (98 ft) or shorter

(10 mm (3/8 inch), 15 mm (1/2 inch))

Outside diameter

11.4 mm (0.45 inch)

MODEL SELECTION

MagneW Two-wire PLUS

Model MTG18A - I II III IV V VI VII VIII IX X XI - XII XIII - Options (some options can be selected per each model)

Basic model no.

Selections

Optional selections Options

MTG18A											
I	Line size	2.5 mm (0.1 inch) (flange type only)	002	*1							
		5 mm (0.2 inch) (flange type only)	005	*1							
		10 mm (3/8 inch) (flange type only)	010	*1							
		15 mm (0.5 inch) (flange type only)	015	*1							
		25 mm (1 inch)	025								
		40 mm (1½ inches)	040								
		50 mm (2 inches)	050								
		65 mm (2½ inches)	065								
		80 mm (3 inches)	080								
		100 mm (4 inches)	100								
		150 mm (6 inches) (flange type only)	150								
200 mm (8 inches) (flange type only)	200										
II	Lining	PFA		P							
III	Pipe connection	Wafer JIS10K		11							
		Wafer JIS16/20K		12							
		Wafer JIS30K		13							
		Wafer ANSI 150		21							
		Wafer ANSI 300		22							
		Wafer DIN PN10		41							
		Wafer DIN PN16		42							
		Wafer DIN PN25		43							
		Wafer DIN PN40		44							
		Flange JIS10K		J1							
		Flange JIS20K		J2							
		Flange JIS30K		J3							
		Flange JIS10K for 10 mm size flange	*2	J4							
		Flange JIS20K for 10 mm size flange	*2	J5							
		Flange ANSI 150		A1							
		Flange ANSI 300		A2							
		Flange DIN PN10		D1							
		Flange DIN PN16		D2							
Flange DIN PN25		D3									
Flange DIN PN40		D4									
IV	Electrode	SUS316L		L							
		ASTM B574 (Hastelloy C-276 equivalent)		C							
		Titanium		K							
		Zirconium		H							
		Tantalum		T							
		Nickel		N							
		Platinum-iridium		P							
V	Grounding ring	SUS316		S							
		ASTM B575 (Hastelloy C-276 equivalent)		C							
		Titanium		K							
		Zirconium		H							
		Tantalum		T							
		Platinum		P							
		Nickel		N							
VI	Wiring connection	G1/2 internal thread		A							
		G1/2 internal thread with plastic water tight gland		B							
		G1/2 internal thread with brass Ni-plated watertight gland		C							
		1/2NPT internal thread (must be selected for FM approval)*4		D							
		CM20 internal thread		E							
		G1/2 internal thread with two plastic watertight glands		J							
		G1/2 internal thread with two brass Ni-plated watertight gland		K							
VII	Face-to-face dimension	Standard		A							
		Replacement for SMT3000 (for wafer type 40 to 100 mm)		S							
VIII	Installation / Display direction	Horizontal piping / Right side viewed from upstream		A							
		Horizontal piping / Left side viewed from upstream		B							
		Horizontal piping / Downstream side		C							
		Horizontal piping / Upstream side		D							
		Vertical piping / Right side of piping / Flow direction: Upward		E							
Vertical piping mounting / Left side of piping / Flow direction: Upward		F									
IX	Calibration	Standard		A							
X	Output / communication	Volume flow 4-20mA DC output/with SFC communication		A							
		Volume flow DE output/with communication		C							
		Volume flow 4-20mA DC output with HART communication		H							
XI	Approval/ Certification	None		X							
		FM approval, Class I, II, III, Division 1, Groups A, B, C, D, E, F & G, T4 CSA certification, Class I, II, III, Division 1, Groups A, B, C, D, E, F & G, T4	*5	1							
		FM approval, NI for Class I, II, III, Division 2, Groups A, B, C, D, F & G, T4 CSA certification, Class I, II, III, Division2, Groups A, B, C, D, E, F & G, T4	*5	2							

X	None		Options
A	Test report		
B	Traceability certificate		
C	Material certificate (electrode/grounding ring)		
G	Gasket for plastic piping		
J	Tropical treatment		
K	with tagging on the converter housing *3		
L	with tag number plate wired to the flowmeter		
X	Finish / paint	Standard paint	XII
2		Corrosion-proof paint	
X	Bolt and nut	None	XIII
2		SUS304 (only for wafer type)	

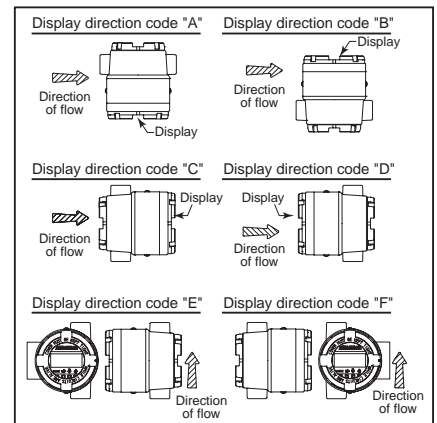

Note) *1: Flange of size 2.5 to 15 mm detector is 15 mm flange.
 *2: Available for size 2.5 to 10 mm detector.
 *3: Must be selected if tagging is required.
 *4: Must select "Approval 1 or 2".
 *5: Must select "Wiring connection D".

MagneW Two-wire PLUS Wafer/Flange remote type converter

Model MTG14C - I II III IV - Options (some options can be selected per each model)

Basic model no.

		Selections				Options
MTG14C						-
I	Analog output / communication	Volume flow 4-20 mA DC output / with SFC communication	A			
		Volume flow DE output / with communication	C			
		Volume flow 4-20 mA DC output / with HART communication	H			
II	Wiring connection	G1/2 internal thread	A			
		G1/2 internal thread with a plastic water-tight gland	B			
		G1/2 internal thread with a brass Ni-plated water-tight gland	C			
		1/2NPT internal thread	D			
		CM20 internal thread	E			
III	Converter mounting	Wall mounting with standard bracket		G		
		2-inch pipe mounting with standard bracket		H		
IV	Approval	None			X	
		FM approval, Class I, II, III, Division 2, Groups A, B, C, D, F & G, T4		*2	2	
		CSA certification, Class I, II, III, Division 2, Groups A, B, C, D, E, F & G, T4				
						-
V	Option	None				X
		Traceability certificate				B
		With the Tag number plate on the converter housing			*1	K
		Corrosion-proof paint				2

Note) *1: Must be selected if tagging is required.

*2: Must select "Wiring connection D".

MagneW Two-wire PLUS Wafer/Flange remote type cable

Model SMC11 - I II III

Basic model no.

		Selections		
SMC11				
I	Cable	2 m (6 feet 8 inches)	02	
		3 m (10 feet)	03	
		4 m (13 feet 4 inches)	04	
		5 m (16 feet 8 inches)	05	
		10 m (33 feet 4 inches)	10	
		15 m (50 feet)	15	
		20 m (66 feet 8 inches)	20	
		30 m (100 feet)	30	
		40 m (133 feet 4 inches)	40	
		50 m (166 feet 8 inches)	50	
		60 m (200 feet)	60	
		70 m (233 feet 4 inches)	70	
		II	Terminals for detector	With terminals
III	Terminals for converter	With terminals		A

MagneW Two-wire PLUS Wafer/Flange remote type detector

Model MTG18B - I II III IV V VI VII VIII IX - Options (some options can be selected per each model)

Basic model no.

Selections

Options

MTG18B									
I	Diameter	10 mm (3/8 inch)	010					Options	
		15 mm (1/2 inch)	015						
		25 mm (1 inch)	025						
		40 mm (1½ inches)	040						
		50 mm (2 inches)	050						
		65 mm (2½ inches)	065						
		80 mm (3 inches)	080						
		100 mm (4 inches)	100						
		150 mm (6 inches)	150						
		200 mm (8 inches)	200						
II	Lining	PFA		P					
III	Pipe connection	Wafer JIS10K					11		
		Wafer JIS16/20K						12	
		Wafer JIS30K							13
		Wafer ANSI 150							21
		Wafer ANSI 300							22
		Wafer DIN PN10							41
		Wafer DIN PN16							42
		Wafer DIN PN25							43
		Flange JIS10K							J1
		Flange JIS20K							J2
		Flange JIS30K							J3
		Flange JIS10K for 10 mm size flange							J4
		Flange JIS20K for 10 mm size flange							J5
		Flange ANSI 150							A1
		Flange ANSI 300							A2
		Flange DIN PN10							D1
Flange DIN PN16							D2		
Flange DIN PN25							D3		
IV	Electrode	SUS316L						L	
		ASTM B574 (Hastelloy C-276 equivalent)						C	
		Titanium						K	
		Zirconium						H	
		Tantalum						T	
		Nickel						N	
		Platinum-iridium						P	
V	Grounding ring	SUS316						S	
		ASTM B575 (Hastelloy C-276 equivalent)						C	
		Titanium						K	
		Zirconium						H	
		Tantalum						T	
		Platinum						P	
VI	Wiring connection	G1/2 internal thread						A	
		G1/2 internal thread with plastic water-tight gland						B	
		G1/2 internal thread with brass Ni-plated water-tight gland						C	
		1/2NPT internal thread						D	
		CM20 internal thread						E	
VII	Face-to-face dimension	Standard						A	
		Yamatake SMT3000 wafer type						S	
VIII	Calibration	Standard calibration						A	
IX	Approval/ Certification	None						X	
		FM approval, NI for Class I, II, III, Division 2, Groups A, B, C, D, F & G, T4 CSA certification, Class I, II, III, Division 2, Groups A, B, C, D, E, F & G, T4							*3 2

Note)

*1: Must be selected if tagging is required.

*2: Available for wafer type.

*3: Must select "Wiring connection D".

DIMENSIONS

All dimensions are in millimeters, dimensions in brackets () are in inches (inch).

Model MTG18A - Flange type size 2.5 mm (0.1 inch) to 15 mm (1/2 inch)
- Flange type size 25 mm (1 inch)

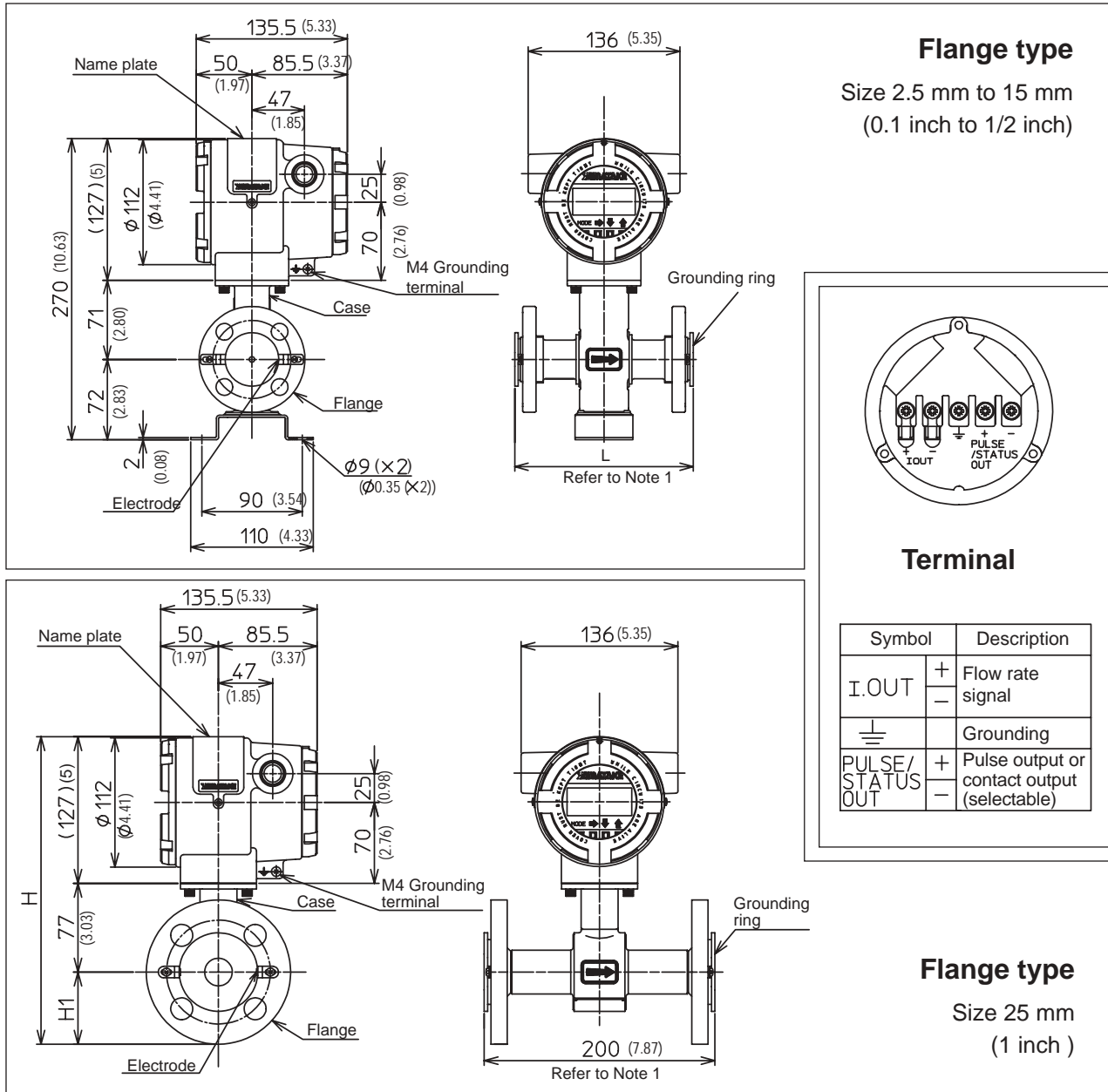

*Note 1 • When grounding ring material is SUS316, gasket dimension is not included to the face-to-face dimension.
 • When grounding ring material is other than SUS316, a 3 mm of Teflon gasket dimension is included to the face-to-face dimension.*

Table 1

Size mm (inch)	Model no.		J1	J2	J3	J4	J5	A1	A2	D1/D2	D3/D4
			JIS					ANSI		DIN	
	Flange rating		10K	20K	30K	10K 10 mm flange	20K 10 mm flange	150	300	PN 10/16	PN 25/40
2.5 to 10 (0.1 to 3/8)	Dimension	L	160	160	160	160	160	160 (6.3)	160 (6.3)	160	160
	Weight	(kg)	6.8	7	8	6.7	6.8	6.4 (14.1 lb)	6.9 (15.2 lb)	6.9	7.1
15 (1/2)	Dimension	L	200	200	200	200	200	200 (7.87)	200 (7.87)	200	200
	Weight	(kg)	7	7.2	8.2	6.9	7	6.6 (14.6 lb)	7.1 (15.7 lb)	7.1	7.3
25 (1)	Dimension	H	267	267	269	-	-	258 (10.16)	266 (10.47)	262	262
		H1	63	63	65	-	-	54 (2.13)	62 (2.44)	58	58
	Weight	(kg)	9.2	9.5	10.3	-	-	8.4 (18.5 lb)	9.5 (20.9 lb)	9.1	9.4

Model MTG18A - Flange type size 40 mm (1½ inch) to 100 mm (4 inches)

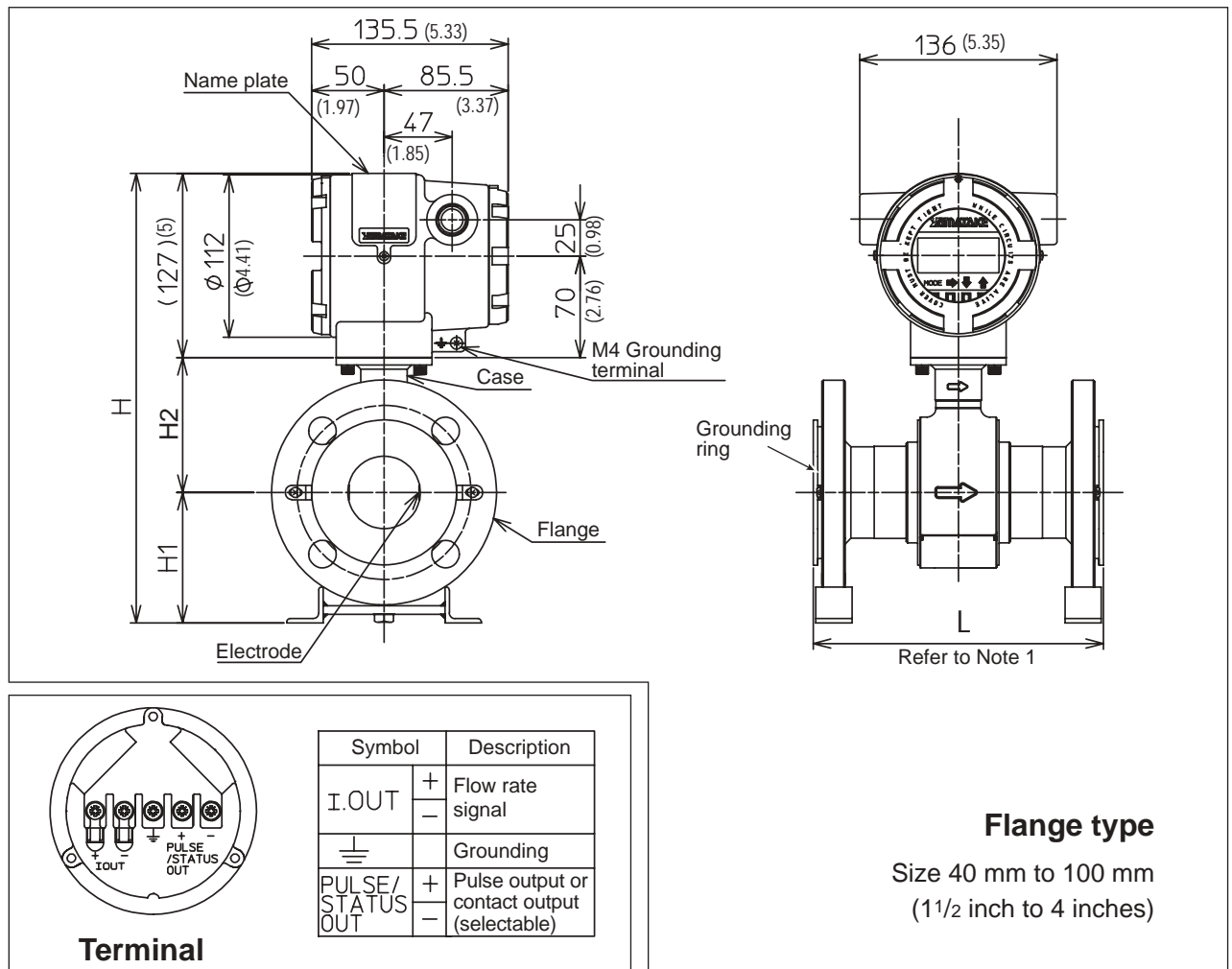

Note 1 • When grounding ring material is SUS316, gasket dimension is not included to the face-to-face dimension.
• When grounding ring material is other than SUS316, a 3 mm of Teflon gasket dimension is included to the face-to-face dimension.

Table 2

Size mm (inches)	Model no.		J1	J2	J3	A1	A2	D1/D2	D3/D4
			JIS			ANSI		DIN	
	Flange rating		10K	20K	30K	150	300	PN 10/16	PN 25/40
40 (1.5)	Dimension	L	200	200	200	200 (7.87)	200 (7.87)	200	200
		H	296	296	307	288 (11.34)	305 (12.01)	302	302
		H1	85	85	96	77 (3.03)	94 (3.7)	91	91
		H2	84	84	84	84 (3.31)	84 (3.31)	84	84
	Weight	(kg)	8.3	8.6	11	7.8 (17.2 lb)	10.1 (22.3 lb)	8.7	9.7
50 (2)	Dimension	L	200	200	200	200 (7.87)	200 (7.87)	200	200
		H	310	310	316	308 (12.13)	316 (12.44)	316	316
		H1	90	90	96	88 (3.46)	96 (3.78)	96	96
		H2	93	93	93	93 (3.66)	93 (3.66)	93	93
	Weight	(kg)	11.9	12	13.7	12.3 (27.1 lb)	13.8 (30.4 lb)	13.3	13.8
65 (2.5)	Dimension	L	200	200	200	200 (7.87)	200 (7.87)	200	200
		H	329	329	343	330 (12.99)	388 (13.31)	334	334
		H1	102	102	116	103 (4.06)	111 (4.37)	107	107
		H2	100	100	100	100 (3.94)	100 (3.94)	100	100
	Weight	(kg)	13.9	14	15.7	14.3 (31.5 lb)	15.8 (34.8 lb)	15.3	15.8
80 (3)	Dimension	L	200	200	200	200 (7.87)	200 (7.87)	200	200
		H	345	354	359	346 (13.62)	359 (14.13)	354	354
		H1	110	119	124	113 (4.45)	124 (4.88)	119	119
		H2	108	108	108	108 (4.25)	108 (4.25)	108	108
	Weight	(kg)	14.4	16.7	20.4	17.3 (38.1 lb)	21.3 (47.0 lb)	14.4	16.5
100 (4)	Dimension	L	250	250	250	250 (9.84)	250 (9.84)	250	250
		H	367.5	376.5	384.5	378.5 (14.90)	392.5 (15.45)	373.5	381.5
		H1	120	129	137	131 (5.16)	145 (5.71)	126	134
		H2	120.5	120.5	120.5	120.5 (4.74)	120.5 (4.74)	120.5	120.5
	Weight	(kg)	20.2	23.7	28.6	25.1 (55.3 lb)	34.2 (75.4 lb)	19.6	23.4

Model MTG18A - Flange type size 150 mm (6 inches) and 200 mm (8 inches)

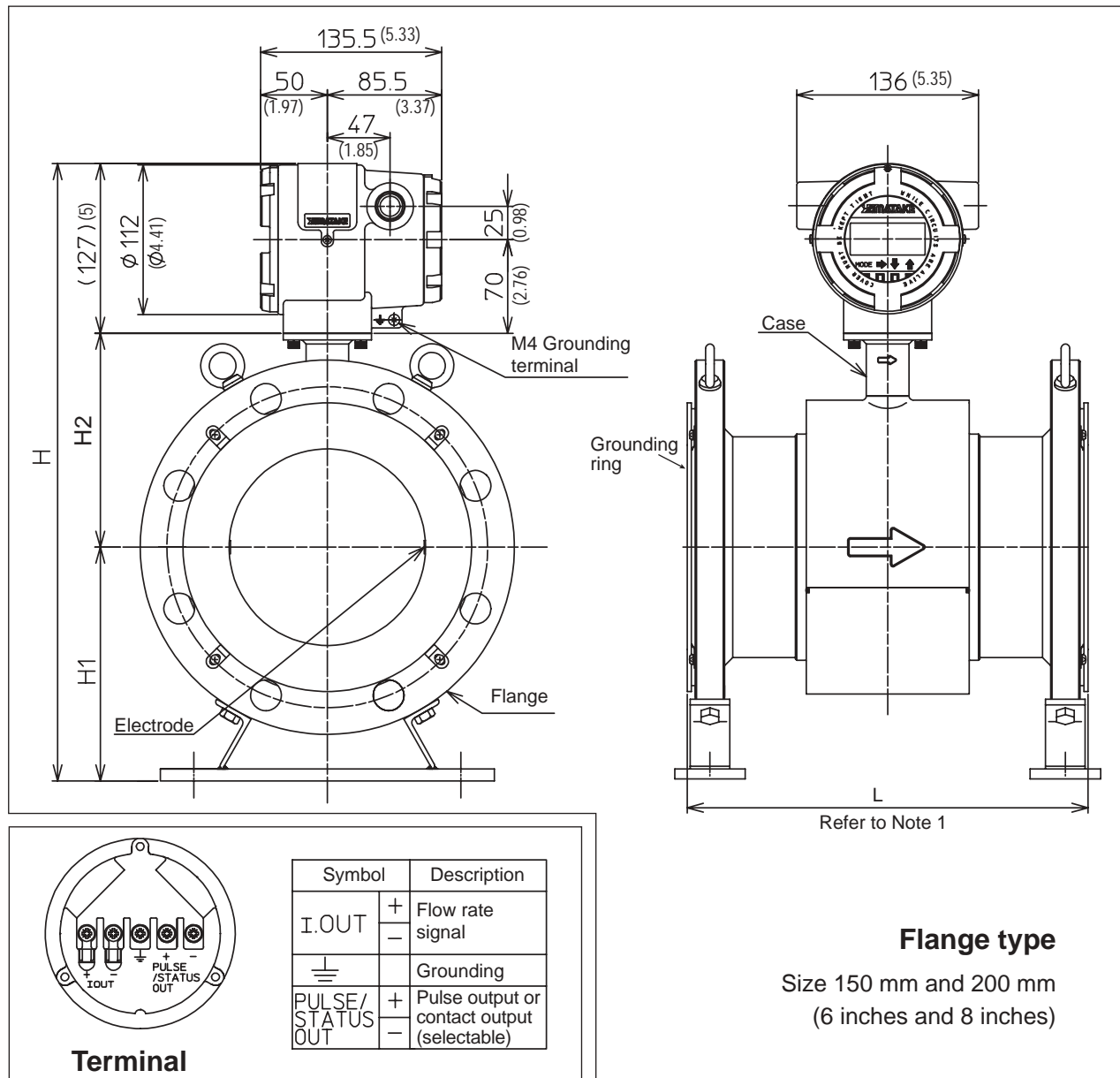

Note 1 • When grounding ring material is SUS316, gasket dimension is not included to the face-to-face dimension.
 • When grounding ring material is other than SUS316, a 3 mm of Teflon gasket dimension is included to the face-to-face dimension.

Table 3

Size mm (inches)	Model no.	Flange rating	J1	J2	J3	A1	A2	D1/D2	D3	D4
			JIS			ANSI		DIN		
	10K	20K	30K	150	300	PN 10/16	PN 25	PN40		
150 (6)	Dimension	L	300	300	300	300 (11.81)	300 (11.81)	300	300	300
		H	462	476	487	461 (18.15)	483 (19.02)	465	473	473
		H1	175	189	200	174 (6.85)	196 (7.72)	178	186	186
		H2	160	160	160	160 (6.3)	160 (6.3)	160	160	160
	Weight	(kg)	34.4	41.7	54.3	37.2 (82.0 lb)	56.2 (123.9 lb)	30.7	38.6	38.6
200 (8)	Dimension	L	350	350	350	350 (13.78)	350 (13.78)	350	350	350
		H	508	515	531	516 (20.31)	537 (21.14)	514	526	534
		H1	196	203	219	204 (8.03)	225 (8.86)	202	214	222
		H2	185	185	185	185 (7.28)	185 (7.28)	185	185	185
	Weight	(kg)	49.8	59.8	87	61.8 (136.2 lb)	90.8 (200.2 lb)	48.1	68.5	72

Model MTG18A - Wafer type size 25 mm (1 inch) to 100 mm (4 inches)

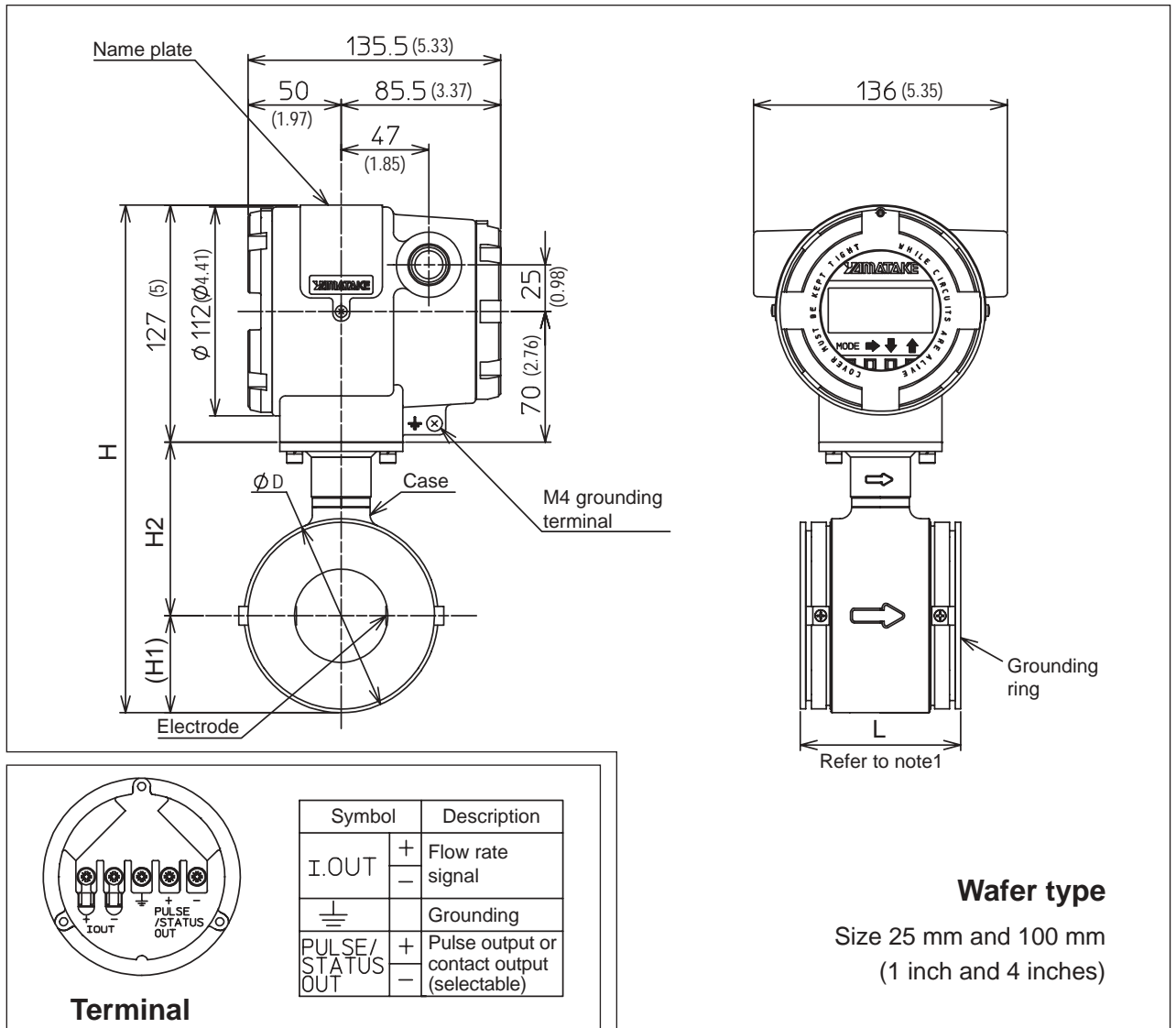

- Note 1 • When grounding ring material is SUS316, gasket dimension is not included to the face-to-face dimension.
 • When grounding ring material is other than SUS316, a 3 mm of Teflon gasket dimension is included to the face-to-face dimension.

Table 4

Flange rating	25 mm (1 inch)		40 mm (1½ inch)		50 mm (2 inches)		65 mm (2½ inches)		80 mm (3 inches)		100 mm (4 inches)	
	A	S	A	S	A	S	A	S	A	S	A	S
Dimension size	L	94 (3.7)	80 (3.15)	98 (3.86)	86 (3.39)	104 (4.09)	96 (3.78)	106 (4.17)	130 (5.12)	120 (4.72)	150 (5.91)	
	H	238 (9.37)	254.5 (10.02)		272 (10.71)		289 (11.38)		302 (11.89)		327 (12.87)	
	H1	34 (1.34)	43.5 (1.71)		52 (2.05)		62 (2.44)		67 (2.64)		79.5 (3.13)	
	H2	77 (3.03)	84 (3.31)		93 (3.66)		100 (3.94)		108 (4.25)		120.5 (4.74)	
	D	68 (2.68)	87 (3.43)		104 (4.09)		124 (4.88)		134 (5.28)		159 (6.26)	
Weight	(kg)	3.7 (8.2 lb)	3.8 (8.4 lb)	4.3 (9.5 lb)	4.4 (9.7 lb)	5.0 (11.0 lb)	5.5 (12.1 lb)	6.4 (14.1 lb)	7.1 (15.7 lb)	8.2 (18.1 lb)	9.2 (20.3 lb)	

Model MTG14C - Converter

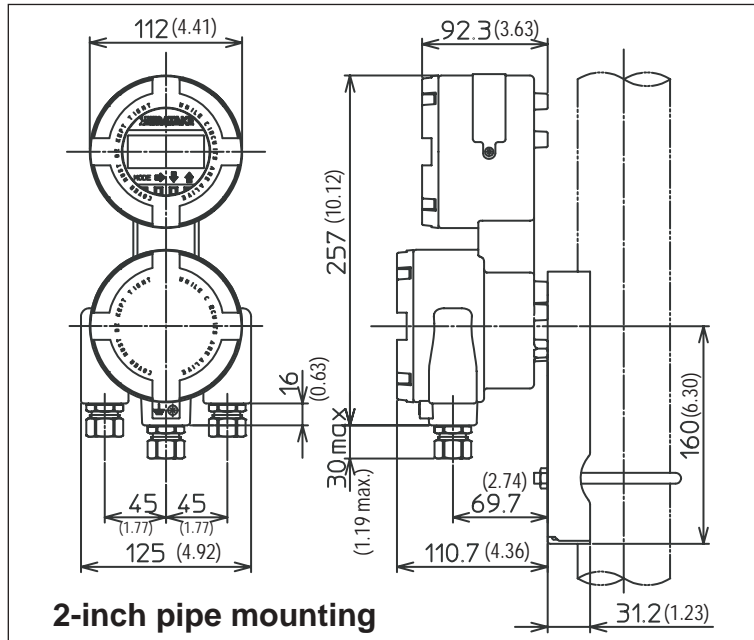
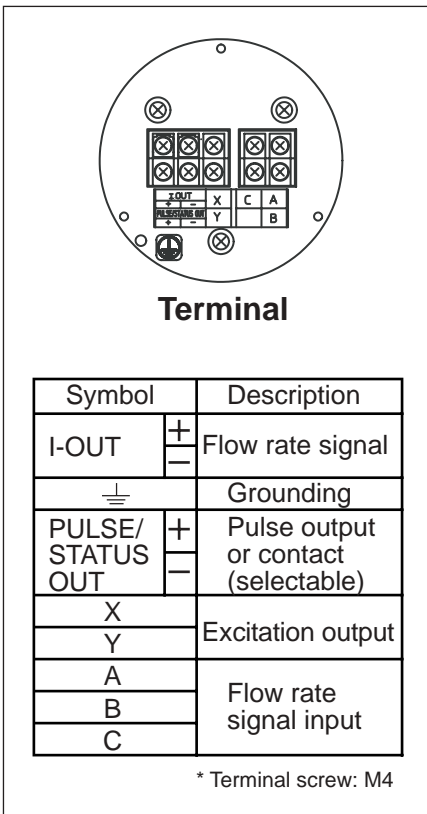
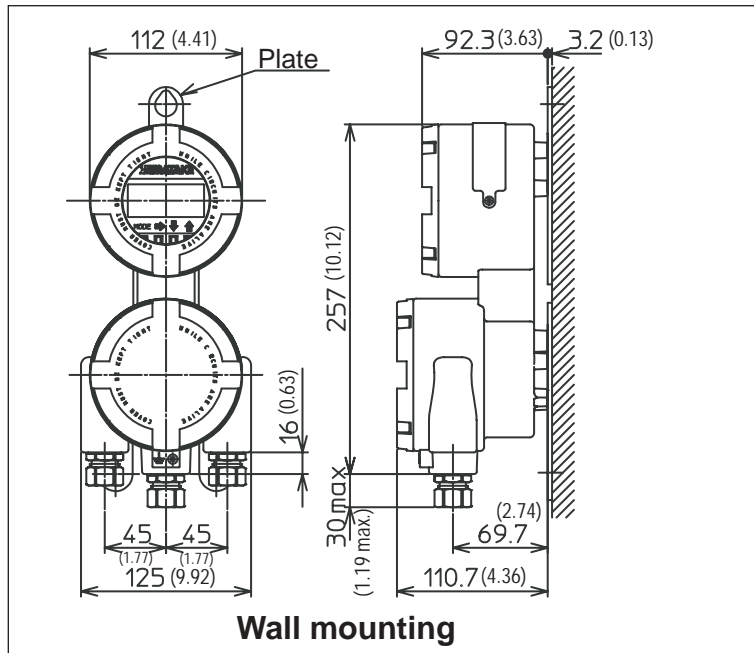
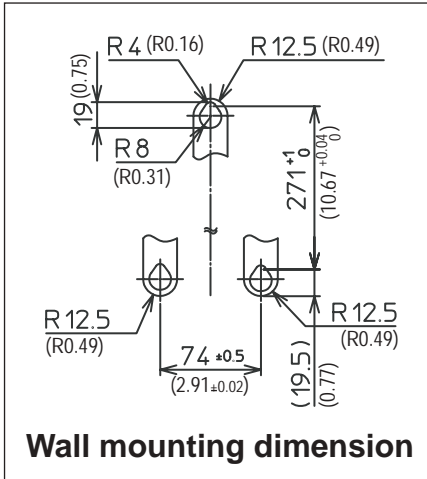

Model SMC11 - Cable

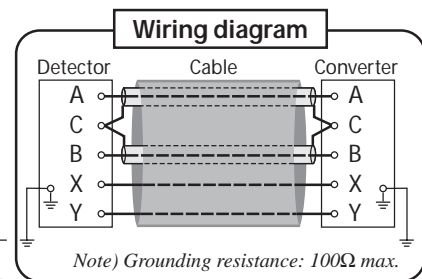
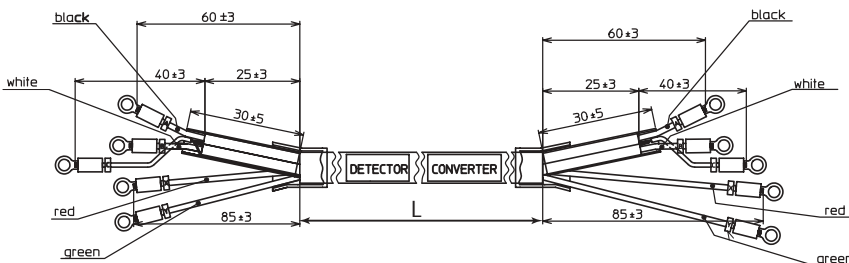

**Model MTG18B - Detector - Flange type size 10 mm (3/8 inch) and 15 mm (1/2 inch)
- Flange type size 25 mm (1 inch)**

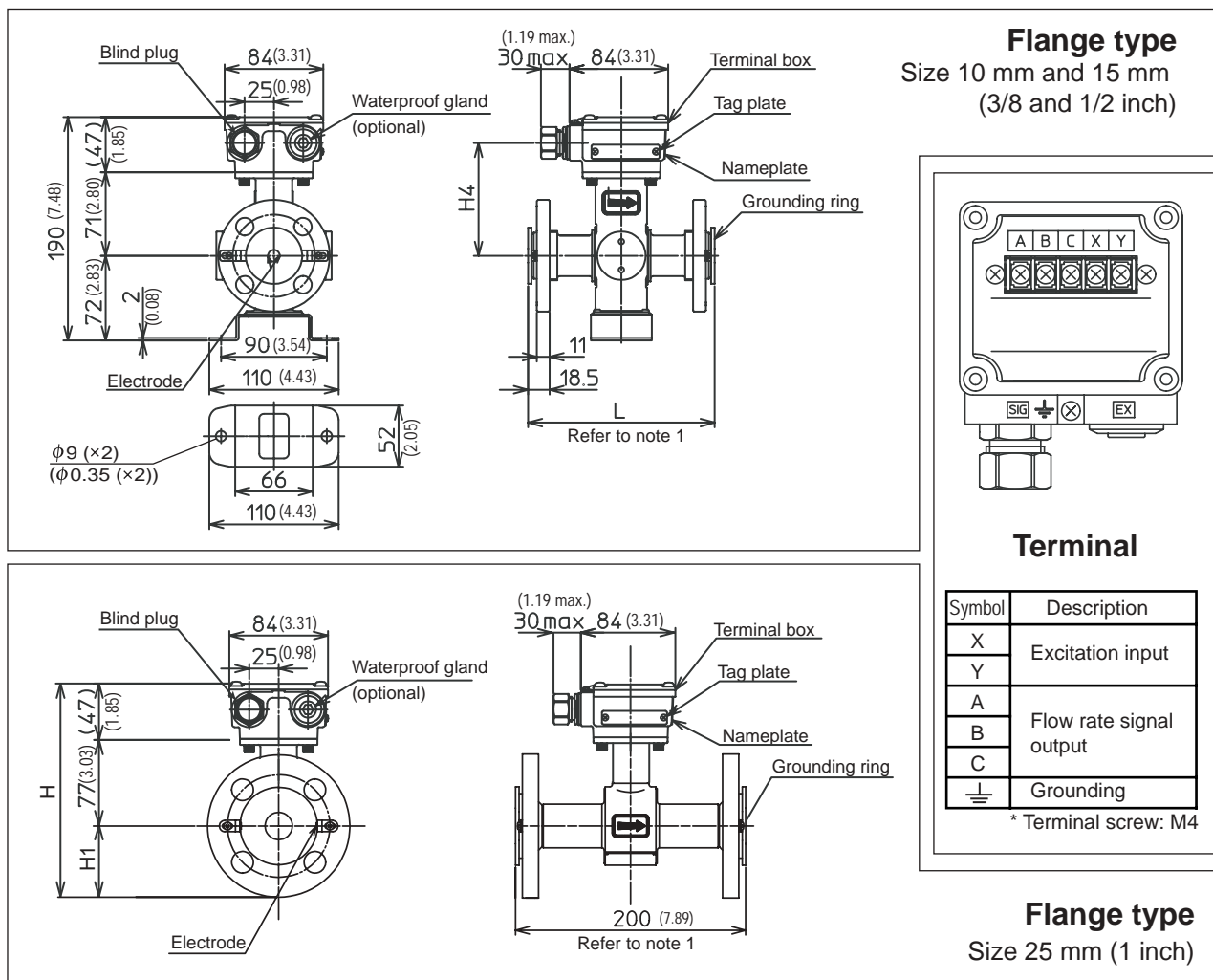

Note 1 • When grounding ring material is SUS316, gasket dimension is not included to the face-to-face dimension.
• When grounding ring material is other than SUS316, a 3 mm of Teflon gasket dimension is included to the face-to-face dimension.

Table 5

Size mm (inches)	Model no.		J1	J2	J3	J4	J5	A1	A2	D1/D2	D3/D4
	Flange rating		JIS					ANSI		DIN	
			10K	20K	30K	10K 10 mm flange	20K 10 mm flange	150	300	PN 10/16	PN 25/40
10 (3/8)	Dimension	L	160	160	160	160	160	160 (6.3)	160 (6.3)	160	160
	Weight	(kg)	5	5.2	6.2	4.9	5	4.6 (10.1 lb)	5.1 (11.2 lb)	5.1	5.3
15 (1/2)	Dimension	L	200	200	200	200	200	200 (7.87)	200 (7.87)	200	200
	Weight	(kg)	5.2	5.4	6.4	5.1	5.2	4.8 (10.6 lb)	5.3 (11.7 lb)	5.3	5.5
25 (1)	Dimension	H	187	187	189	-	-	188 (7.4)	186 (7.32)	182	182
		H1	63	63	65	-	-	54 (2.13)	62 (2.44)	58	58
	Weight	(kg)	7.4	7.7	8.5	-	-	6.6 (14.6 lb)	7.7 (17.0 lb)	7.3	7.6

Model MTG18B - Detector - Flange type size 40 mm (1½ inch) to 100 mm (4 inches)

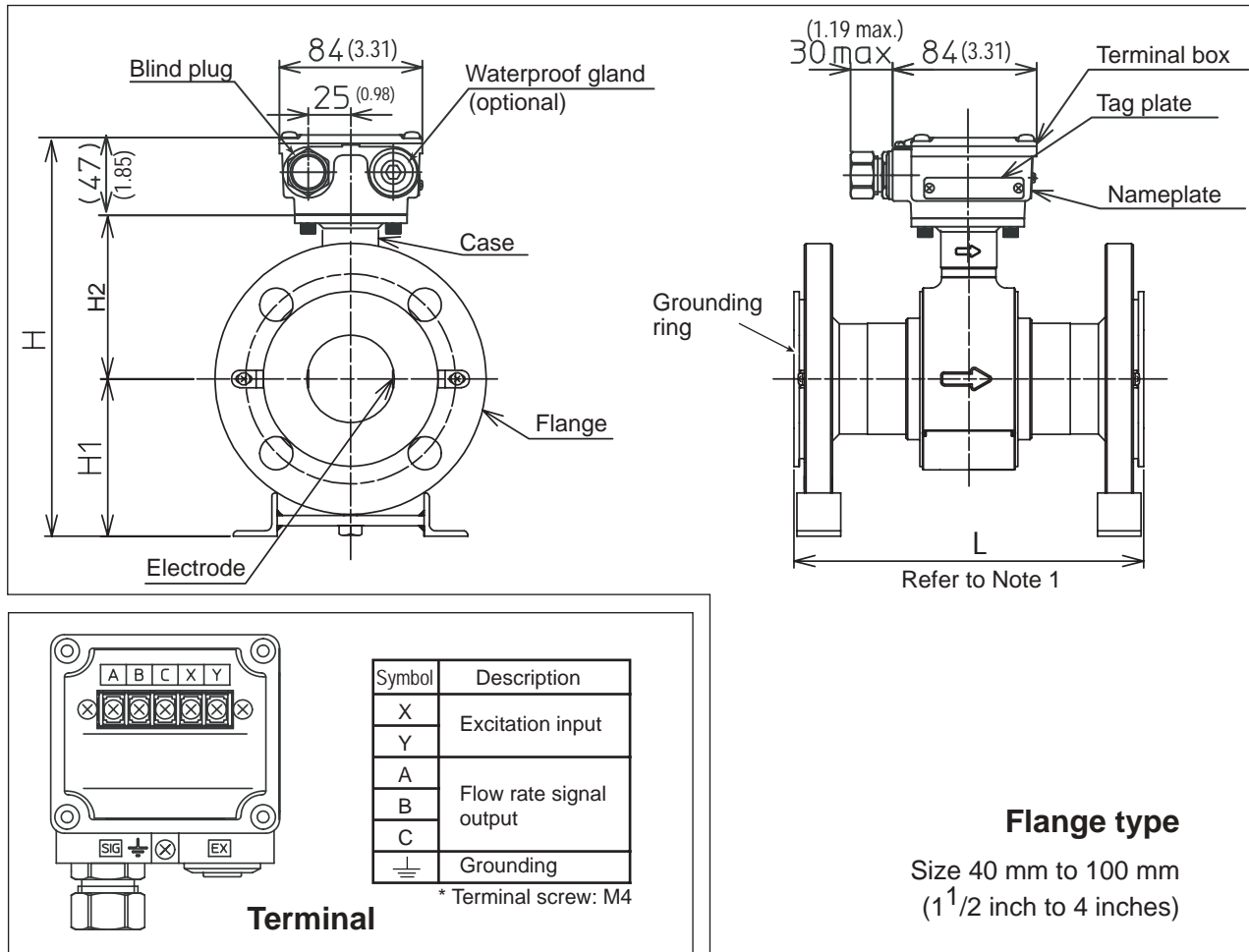

Note 1 • When grounding ring material is SUS316, gasket dimension is not included to the face-to-face dimension.
 • When grounding ring material is other than SUS316, a 3 mm of Teflon gasket dimension is included to the face-to-face dimension.

Table 6

Size mm (inches)	Model no. Flange rating	JIS			ANSI		DIN		
		J1	J2	J3	A1	A2	D1/D2	D3/D4	
		10K	20K	30K	150	300	PN 10/16	PN 25/40	
40 (1.5)	Dimension	L	200	200	200	200 (7.87)	200 (7.87)	200	200
		H	216	216	227	208 (8.19)	225 (8.86)	222	222
		H1	85	85	96	77 (3.03)	94 (3.7)	91	91
		H2	84	84	84	84 (3.31)	84 (3.31)	84	84
	Weight	(kg)	6.5	6.8	9.2	6 (13.2 lb)	8.3 (18.3 lb)	6.9	7.9
50 (2)	Dimension	L	200	200	200	200 (7.87)	200 (7.87)	200	200
		H	230	230	236	228 (8.98)	236 (9.29)	236	236
		H1	90	90	96	88 (3.46)	96 (3.78)	96	96
		H2	93	93	93	93 (3.66)	93 (3.66)	93	93
	Weight	(kg)	10.1	10.2	11.9	10.5 (23.1 lb)	12 (26.5 lb)	11.5	12
65 (2.5)	Dimension	L	200	200	200	200 (7.87)	200 (7.87)	200	200
		H	249	249	263	250 (9.84)	258 (10.16)	254	254
		H1	102	102	116	103 (4.06)	111 (4.37)	107	107
		H2	100	100	100	100 (3.94)	100 (3.94)	100	100
	Weight	(kg)	12.1	12.2	13.9	12.5 (27.6 lb)	14 (30.9 lb)	13.5	14
80 (3)	Dimension	L	200	200	200	200 (7.87)	200 (7.87)	200	200
		H	265	274	279	266 (10.47)	279 (10.98)	274	274
		H1	110	119	124	113 (4.45)	124 (4.88)	119	119
		H2	108	108	108	108 (4.25)	108 (4.25)	108	108
	Weight	(kg)	16.6	14.9	18.6	15.5 (34.2 lb)	19.5 (43.0 lb)	12.6	14.7
100 (4)	Dimension	L	250	250	250	250 (9.84)	250 (9.84)	250	250
		H	287.5	296.5	304.5	298.5 (11.75)	312.5 (12.30)	293.5	301.5
		H1	120	129	137	131 (5.16)	145 (5.71)	126	134
		H2	120.5	120.5	120.5	120.5 (4.74)	120.5 (4.74)	120.5	120.5
	Weight	(kg)	18.4	21.9	26.8	23.3 (51.4 lb)	32.4 (71.4 lb)	17.8	21.6

Model MTG18B - Detector - Flange type size 150 mm (6 inches) and 200 mm (8 inches)

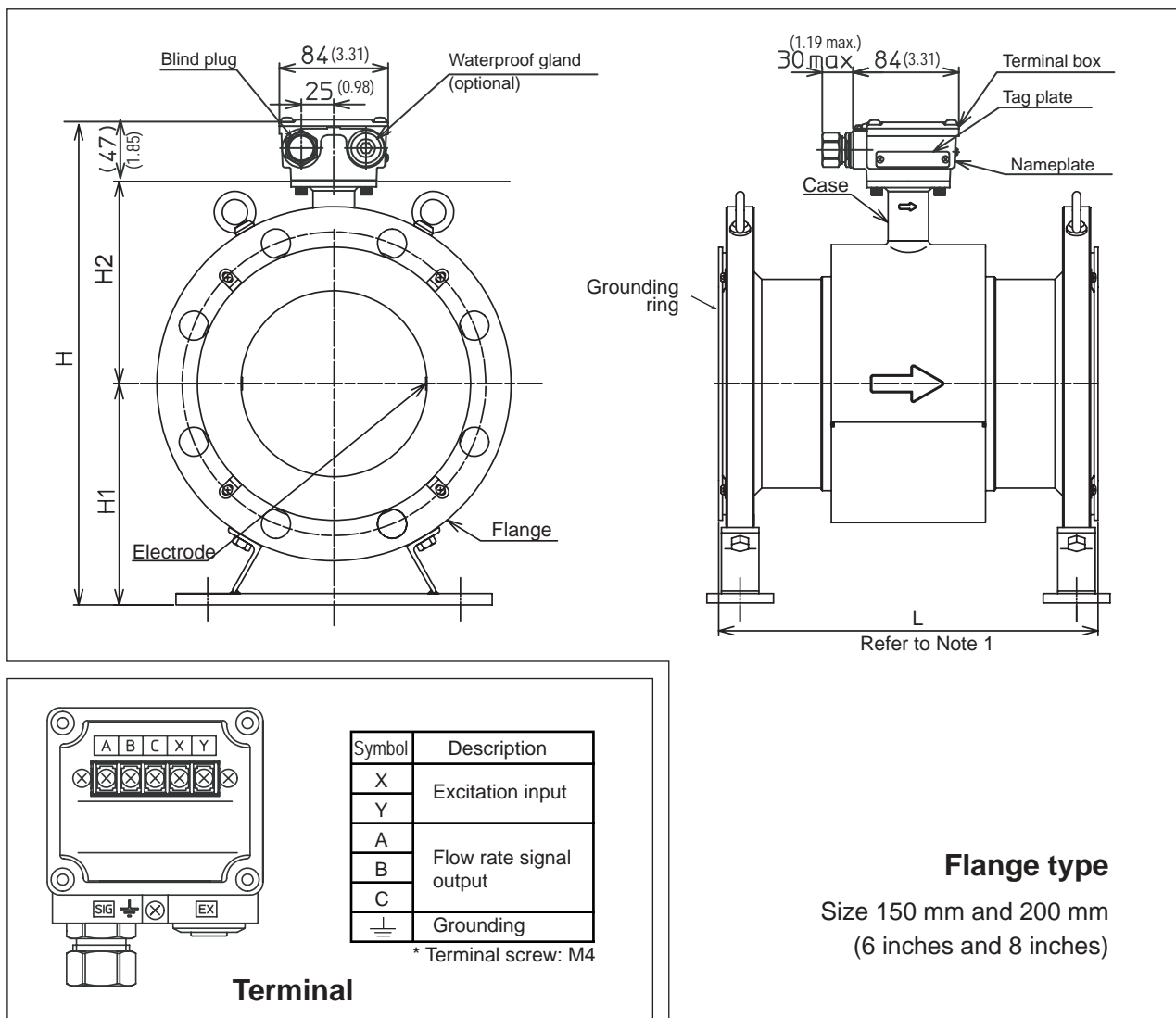

Note 1 • When grounding ring material is SUS316, gasket dimension is not included to the face-to-face dimension.
 • When grounding ring material is other than SUS316, a 3 mm of Teflon gasket dimension is included to the face-to-face dimension.

Table 7

Size mm (inches)	Model no. Flange rating	J1	J2	J3	A1	A2	D1/D2	D3	D4	
		JIS			ANSI		DIN			
		10K	20K	30K	150	300	PN 10/16	PN 25	PN 40	
150 (6)	Dimension	L	300	300	300	300 (11.81)	300 (11.81)	300	300	300
		H	382	396	407	381 (15)	403 (15.87)	385	393	393
		H1	175	189	200	174 (6.85)	196 (7.72)	178	186	186
		H2	160	160	160	160 (6.3)	160 (6.3)	160	160	160
	Weight	(kg)	32.6	39.9	52.5	35.4 (78 lb)	54.4 (119.9 lb)	28.9	36.8	36.8
200 (8)	Dimension	L	350	350	350	350 (13.78)	350 (13.78)	350	350	350
		H	428	435	451	436 (17.17)	457 (17.99)	434	446	454
		H1	196	203	219	204 (8.03)	225 (8.86)	202	214	222
		H2	185	185	185	185 (7.28)	185(7.28)	185	185	185
	Weight	(kg)	48	58	85.2	60 (132.3 lb)	89 (196.2 lb)	46.3	66.7	70.2

Model MTG18B - Detector - Wafer type size 25 mm (1 inch) to 100 mm (4 inches)

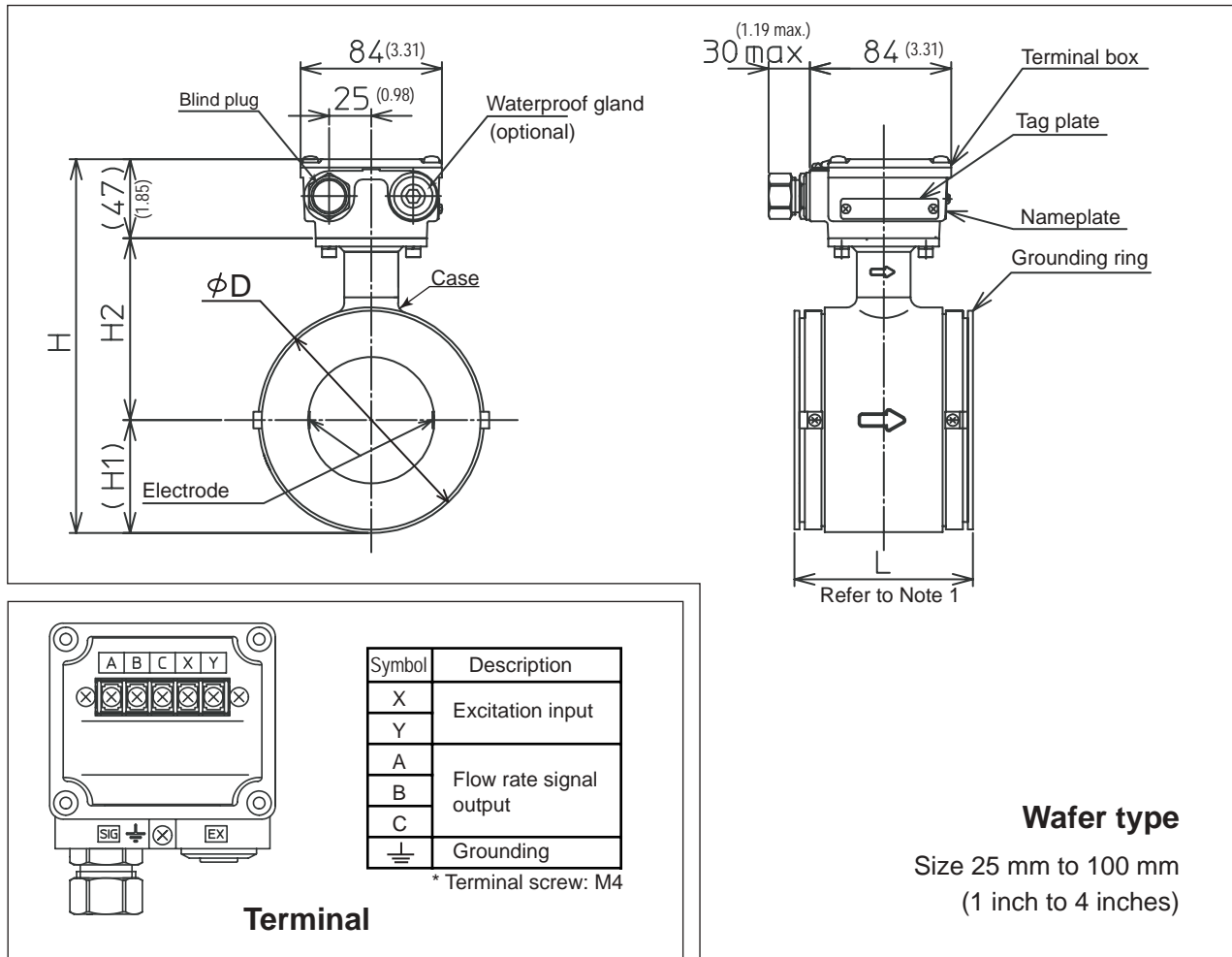

Note 1 • When grounding ring material is SUS316, gasket dimension is not included to the face-to-face dimension.
 • When grounding ring material is other than SUS316, a 3 mm of Teflon gasket dimension is included to the face-to-face dimension.

Table 8

Flange rating	25 mm (1 inch)		40 mm (1½ inch)		50 mm (2 inches)		65 mm (2½ inches)		80 mm (3 inches)		100 mm (4 inches)	
	A	S	A	S	A	S	A	S	A	S	A	S
Dimension size	L	94 (3.7)	80 (3.15)	98 (3.86)	86 (3.39)	104 (4.09)	96 (3.78)	106 (4.17)	130 (5.12)	120 (4.72)	150 (5.91)	
	H	158 (6.22)	174.5 (6.87)		192 (7.56)		209 (8.23)	222 (8.74)		247 (9.72)		
	H1	34 (1.34)	43.5 (1.71)		52 (2.05)		62 (2.44)	67 (2.64)		79.5 (3.13)		
	H2	77 (3.03)	84 (3.31)		93 (3.66)		100 (3.94)	108 (4.25)		120.5 (4.74)		
	D	68 (2.68)	87 (3.43)		104 (4.09)		124 (4.88)	134 (5.28)		159 (6.26)		
Weight	(kg)	2	2	2.5	2.6	3.2	3.7	4.6	5.3	6.4	7.4	
		(4.4 lb)	(4.4 lb)	(5.5 lb)	(5.7 lb)	(7.1 lb)	(8.2 lb)	(10.1 lb)	(11.7 lb)	(14.1 lb)	(16.3 lb)	



Savemation

Saving through Automation

Yamatake Corporation

Totate international Building
 2-12-19 Shibuya
 Shibuya-ku, Tokyo 150-8316
 Japan
 Tel : 81-3-3486-2310
 Fax : 81-3-3486-2593